

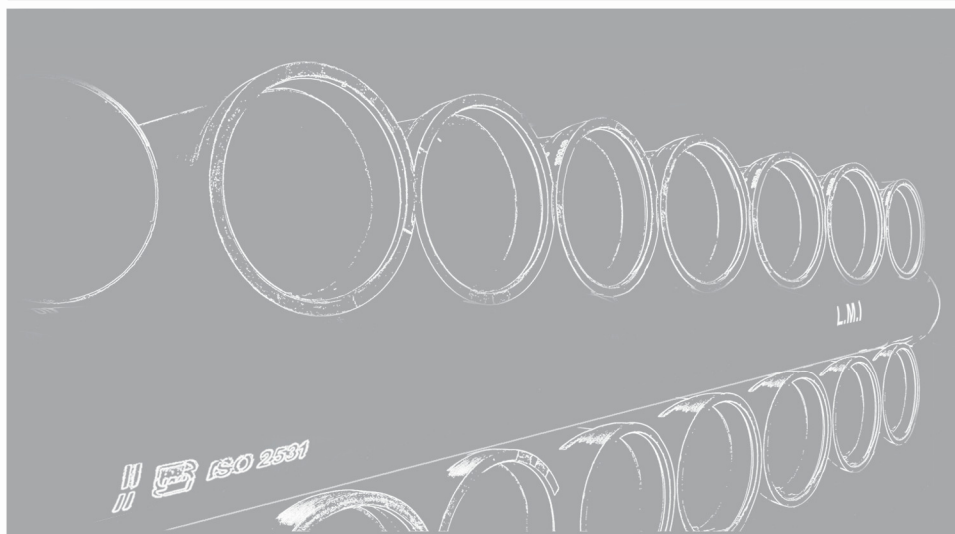

LMI Co.

Luleh va Mashinsazi Iran (Public Joint Stock Company)
With more than sixty years of experience in production and development

Ductile Iron Pipes



DN100 - DN2000

- **K9** (ISO 2531 : 1998)
- **C-Class** (ISO 2531 : 2009)



- **Headquarters and Factory No. 1:**
Chahardangeh, Ayatollah Saeedi Highway, Tehran, Iran.
Phone: **+98 21 51093** Fax: **+98 21 55242968**
- **Export Unit:**
Phone: **+98 21 51092510** Fax: **+98 21 55246196**
- **Factory No. 2:**
End of Negarestan Blvd, Shams Abad Industrial City,
Qom Highway, Tehran, Iran.
Phone: **+98 21 56231666** Fax: **+98 21 56231667**
Website: **www.lmico.net**
Email: **info@lmico.net**
Email of Export Department: **sales@lmico.net**





LMI Co.

Ductile Iron Pipes

So far, water transportation and sanitation have always been of interest to developing countries, and this importance is twice for low water areas such as Iran and the Middle East.

These areas require a large water distribution network, and the pipe is the most important part of that.

Over the years, relevant Iranian organizations had bought and used ductile iron pipes, which are the best option for the health of drinking water, from European and American countries and used in distribution network.

LMI Co., with the aim of eliminating the dependence to foreign countries and supplying some of the equipment used in the water industry, has started its activities since 1957 and during the last half-century, has been as a pioneer of this industry and supplier of Ductile Iron Pipes and fittings (with the same quality as the best global manufacturers).

Currently, LMI Co. in Tape Sefid and Shams Abad factories, produce ductile iron pipes with a diameter from 100 to 2000 mm and an annual capacity of 140,000 tons in accordance with the latest International standards, which in addition to Domestic demand has also covered the export markets of the region.

Standards

ISO 2531:2009

Ductile iron pipes, fittings, accessories and their joints for water applications

ISO 2531:1998

Ductile iron pipes, fittings, accessories and their joints for water or gas applications

INSO 3732

National standard for ductile iron pipes, fittings and their accessories for water applications

EN 545

Ductile iron pipes, fittings, accessories and their joints for water pipelines requirements and test methods

ISO 4179

Ductile iron pipes and fittings for pressure and non-pressure pipelines - cement mortar lining

ISO 8179

Ductile iron pipes - external zinc - based coating - part 1; metallic zinc with finishing layer

ISO 4633

Rubber seals - joint rings for water supply, drainage and sewerage pipelines, specification for materials

DIN 28603

Ductile iron pipes and fittings, push in joints, survey, sockets and gaskets

ISO 6708

Pipe work components - definition and selection of DN (nominal size)

ISO 7268

Pipe components - definition of nominal pressure



Advantages of Ductile Iron Pipes

- High corrosion resistance
- Long lifetime
- High value of scrap
- Desirable mechanical properties (tensile strength, elongation and high buckling strength)
- Suitable for applications with high stress and high surge pressure because of its high strength, excellent elastic properties and ductility
- High resistance to traffic loads and land slide
- High impact resistance
- Insensitivity to ovality in compar with other pipe types
- Less Sensitivity to trench preparation
- Proper angular and longitudinal displacement
- High installation speed
(atmospheric agents have less effect on the installation of ductile iron pipes)
- Ability to cut and branching if necessary
- Not sensitive to sunlight and UV rays
- High resistance to human and plant factors
- Insensitivity to temperature
- High hydraulic flow coefficient
(due to the internal cement lining with centrifugal method)
- Low maintenance costs (no need for cathodic protection)
- Less pumping costs due to a larger nominal diameter and a high coefficient for hydraulic flow
- Traceability using metal detectors

K9 Ductile Iron Pipes (ISO 2531 : 1998)

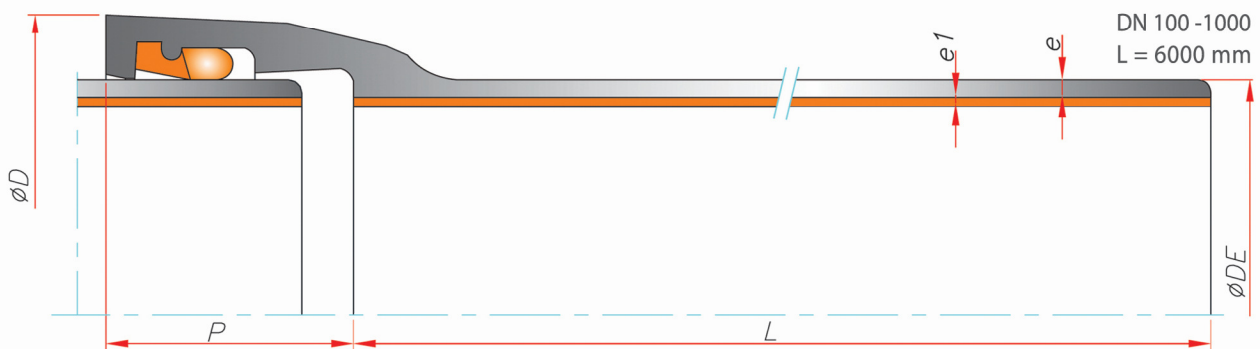

Nominal pipe Diameter DN	External pipe Diameter DE	External Diameter of the Socket $\varnothing D$	Socket Length P	Cement Thickness e1	Pipe Thickness e	Mass per meter (Inc. Socket)		Total mass of 6m long pipe (Inc. Socket)	
						Pipe	Pipe and cement	Pipe	Pipe and cement
100	118	163	88	3	6	15.6	17.7	94	106
150	170	217	94	3	6	22.9	26.1	137	156
200	222	278	100	3	6.3	31.8	36.1	191	217
250	274	332	105	3	6.8	42.8	48.2	257	289
300	326	393	110	3	7.2	54	60.4	324	363
350	378	442	110	5	7.7	67.3	79.7	404	478
400	429	500	110	5	8.1	80.3	94.4	482	566
500	532	604	120	5	9	111	128.6	666	771
600	635	713	120	5	9.9	146.3	167.4	878	1004
700	738	825	150	6	10.8	187.9	217.4	1128	1304
800	842	935	160	6	11.7	234.7	268.4	1408	1611
900	945	1044	175	6	12.6	285	322.8	1710	1937
1000	1048	1153	185	6	13.5	339.8	381.9	2039	2291

* Dimensions in mm, weights in kg and pressures are in bar presented.

** All dimensions and weights are included regardless of tolerances.

Ductile Iron Pipes (ISO 2531 : 1998) K9

LMI Co.

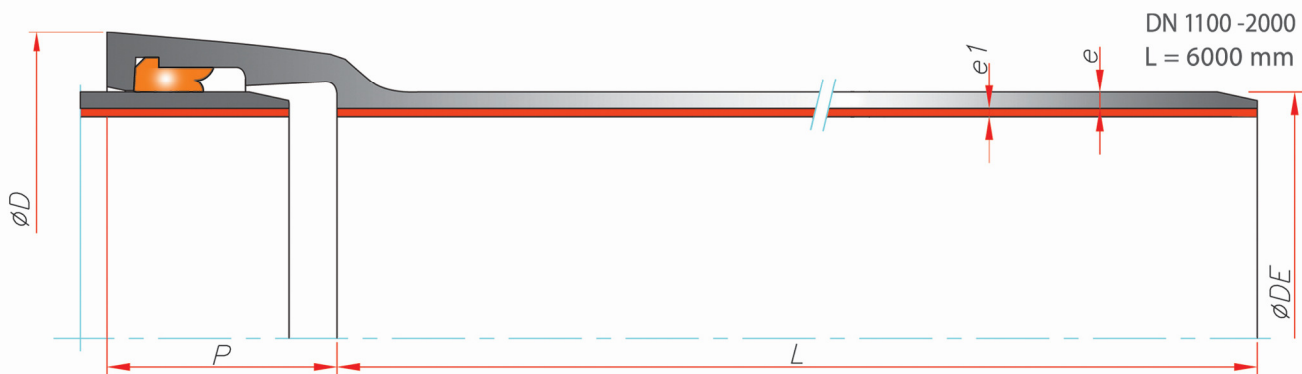

Nominal pipe Diameter DN	External pipe Diameter DE	External Diameter of the Socket ϕD	Socket Length P	Cement Thickness e1	Pipe Thickness e	Mass per meter (Inc. Socket)		Total mass of 6m long pipe (Inc. Socket)	
						Pipe	Pipe and cement	Pipe	Pipe and cement
1100	1152	1261	160	6	14.4	389.1	435.4	2335	2613
1200	1255	1366	165	6	15.3	449.6	500.1	2697	3001
1400	1462	1589	240	9	17.1	598.6	686.9	3592	4121
1500	1565	1697	250	9	18	676.4	771	4059	4626
1600	1668	1806	260	9	18.9	760.2	861.1	4561	5166
1800	1875	2024	270	9	20.7	940.7	1054.2	5644	6325
2000	2082	2242	290	9	22.5	1144.2	1270.3	6865	7622

* Dimensions in mm, weights in kg and pressures are in bar presented.

** All dimensions and weights are included regardless of tolerances.

K9 Allowed Pressure for Ductile Iron Pipes



Allowable Operating Pressure (PFA):

Maximum hydrostatic pressure (no surge pressure), that a component can stand continuously during service.

Allowable Maximum Operating Pressure (PMA):

Maximum hydrostatic pressure (including surge pressure), which a component can safely withstand during service.

Allowable Test Pressure (PEA):

The maximum hydrostatic pressure that a component after installation can withstand for a relatively short period of time to ensure the integrity and rigidity of the pipeline Allowed pressure for K9 Ductile iron pipes Specifications of Ductile iron pipes.



Allowed Pressure for K9 Ductile Iron Pipes



DN	PFA (bar)	PMA (bar)	PEA (bar)
100	85	102	107
150	79	95	100
200	62	74	79
250	54	65	70
300	49	59	64
350	45	54	59
400	42	51	56
500	38	46	51
600	36	43	48
700	34	41	46
800	32	38	43
900	31	37	42
1000	30	36	41
1100	29	35	40
1200	28	34	39
1400	28	33	38
1500	27	32	37
1600	27	32	37
1800	26	31	36
2000	26	31	36







The Embankment Around the Ductile Iron Pipes **K9**



The embankment around the K9 ductile iron pipes will vary according to the working pressure and depth of the trench. Accordingly, 5 different types of embankments are defined as follows.

- 

The trench floor is paved smoothly and without bedding. No special embankment around the pipe is done.
- 

The trench floor is paved smoothly and without bedding. The soil around the pipe is filled up to the middle of the pipe.
- 

The pipe is laid on a soft clay layer at a height of 10 cm. The soil around the pipe is crushed to the height of the canopy.
- 

The pipe is laid on a layer of sand with a minimum thickness of 10cm. around the pipe granular material is poured up to the height of the canopy and is compressed to 80% in accordance with Proctor's standard AASHTO T-99.
- 

A layer of granular materials is dumped at a thickness of 10cm below the pipe to the height of the canopy, and up to 90% are compressed according to Proctor's standard, AASHTO T-99.

Minimum Laying Condition for K9 Ductile Iron Pipes vs Depth of Cover (with traffic load)

H (m)	DN																				
	2000	1800	1600	1500	1400	1200	1100	1000	900	800	700	600	500	400	350	300	250	200	150	100	
0.5	Green	Green	Green	Green	Green	Green	Green	Green	Green	Green	Green	Green	Green	Green	Green	Green	Green	Green	Green	Green	Green
1	Green	Green	Green	Green	Green	Green	Green	Green	Green	Green	Green	Green	Green	Green	Green	Green	Green	Green	Green	Green	Green
1.5	Green	Green	Green	Green	Green	Green	Green	Green	Green	Green	Green	Green	Green	Green	Green	Green	Green	Green	Green	Green	Green
2	Green	Green	Green	Green	Green	Green	Green	Green	Green	Green	Green	Green	Green	Green	Green	Green	Green	Green	Green	Green	Green
2.5	Green	Green	Green	Green	Green	Green	Green	Green	Green	Green	Green	Green	Green	Green	Green	Green	Green	Green	Green	Green	Green
3	Green	Green	Green	Green	Green	Green	Green	Green	Green	Green	Green	Green	Green	Green	Green	Green	Green	Green	Green	Green	Green
3.5	Green	Green	Green	Green	Green	Green	Green	Green	Green	Green	Green	Green	Green	Green	Green	Green	Green	Green	Green	Green	Green
4	Green	Green	Green	Green	Green	Green	Green	Green	Green	Green	Green	Green	Green	Green	Green	Green	Green	Green	Green	Green	Green
4.5	Green	Green	Green	Green	Green	Green	Green	Green	Green	Green	Green	Green	Green	Green	Green	Green	Green	Green	Green	Green	Green
5	Green	Green	Green	Green	Green	Green	Green	Green	Green	Green	Green	Green	Green	Green	Green	Green	Green	Green	Green	Green	Green
5.5	Green	Green	Green	Green	Green	Green	Green	Green	Green	Green	Green	Green	Green	Green	Green	Green	Green	Green	Green	Green	Green
6	Green	Green	Green	Green	Green	Green	Green	Green	Green	Green	Green	Green	Green	Green	Green	Green	Green	Green	Green	Green	Green
7	Green	Green	Green	Green	Green	Green	Green	Green	Green	Green	Green	Green	Green	Green	Green	Green	Green	Green	Green	Green	Green
8	Green	Green	Green	Green	Green	Green	Green	Green	Green	Green	Green	Green	Green	Green	Green	Green	Green	Green	Green	Green	Green
9	Green	Green	Green	Green	Green	Green	Green	Green	Green	Green	Green	Green	Green	Green	Green	Green	Green	Green	Green	Green	Green
10	Green	Green	Green	Green	Green	Green	Green	Green	Green	Green	Green	Green	Green	Green	Green	Green	Green	Green	Green	Green	Green

Note: The full details of the embankment around the ductile iron pipes are available on the website and the technical sheet of L.M.I.Co.

C_{Class} Ductile Iron Pipes (ISO 2531 : 2009)

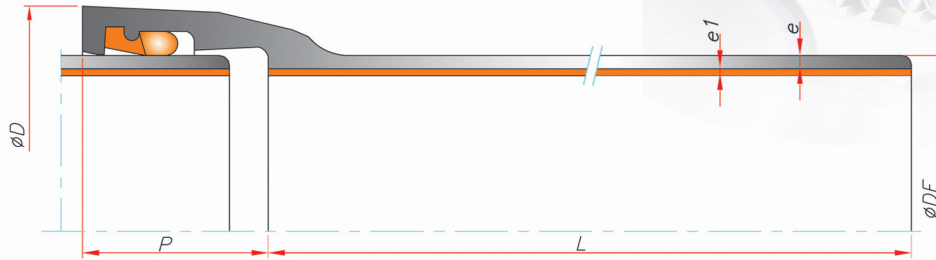

DN 100 -1000
L = 6000 mm

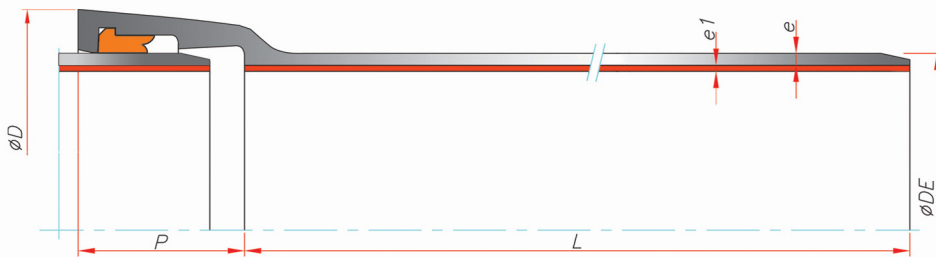

DN 1100 -2000
L = 6000 mm

Ductile Iron Pipes C-Class

Permissible working pressure (PFA)					(C20) 20			(C25) 25			(C30) 30			(C40) 40			(C50) 50		
Nominal pipe Diameter DN	External pipe Diameter DE	External Diameter of the Socket øD	Socket Length P	Cement Thickness e1	Weight			Weight			Weight			Weight of pipe			Weight of pipe		
					Pipes Thickness e	Pipe	pipe and cement	Pipes Thickness e	Pipe	pipe and cement	Pipes Thickness e	Pipe	pipe and cement	Pipes Thickness e	Pipe	pipe and cement	Pipes Thickness e	Pipe	pipe and cement
100	118	163	88	3										4.4	11.8	14.0	4.4	11.8	14.0
150	170	217	94	3										4.5	17.6	20.8	4.5	17.6	20.8
200	222	278	100	3										4.7	24.4	28.7	5.4	27.7	32.0
250	274	332	105	3										5.5	35.3	40.7	6.4	40.5	45.9
300	326	393	110	3						5.1	39.4	45.9	6.2	47.1	53.6	7.4	55.4	61.8	
350	378	442	110	5				5.1	46.3	58.8	6.3	56.0	68.5	7.1	62.5	74.9			
400	429	500	110	5				5.5	56.4	70.6	6.5	65.6	79.8	7.8	77.5	91.7			
500	532	604	120	5				6.5	82.4	100.1	7.5	93.8	111.5	9.3	114.4	132.0			
600	635	713	120	5				7.6	114.8	136.1	8.7	129.9	151.1	10.9	159.9	180.9			
700	738	825	150	6	7.3	132.1	161.9	8.8	156.1	185.7	9.9	173.6	203.2						
800	842	935	160	6	8.1	169.2	203.2	9.6	196.6	230.4	11.1	223.9	257.6						
900	945	1044	175	6	8.9	209.3	247.5	10.6	244.1	282.2	12.3	278.8	316.8						
1000	1048	1153	185	6	9.8	255.8	298.2	11.6	296.7	339.0	13.4	337.5	379.6						
1100	1152	1261	160	6	10.6	294.3	340.9	12.6	344.3	390.7	14.7	396.6	442.9						
1200	1255	1366	165	6	11.4	343.5	394.3	13.6	403.4	454.1	15.8	463.1	513.6						
1400	1462	1589	240	9	13.1	471.8	560.5	15.7	554.3	642.7	18.2	633.4	721.5						
1500	1565	1697	250	9	13.9	537.2	632.3	16.7	632.4	727.1	19.4	723.8	818.2						
1600	1668	1806	260	9	14.8	611.8	713.2	17.7	716.9	817.9	20.6	821.5	922.2						
1800	1875	2024	270	9	16.4	765.7	879.7	19.7	900.1	1013.7	23.0	1034.0	1147.2						
2000	2082	2242	290	9	18.1	945.2	1071.9	21.8	1112.6	1238.8	25.4	1274.8	1400.6						

* Dimensions in mm, weights in kg and pressures are in bar presented

** All dimensions and weights are included regardless of tolerances

***The weights presented in the table are for 1 meter of pipes in length with socket included.

**** Preferred class is specified in green



The Embankment Around the Ductile Iron Pipes C Class

The embankment around the K9 ductile iron pipes will vary according to the working pressure and depth of the trench. Accordingly, 5 different types of embankments are defined as follows.

- Type 1

The trench floor is paved smoothly and without bedding. No special embankment around the pipe is done.
- Type 2

The trench floor is paved smoothly and without bedding. The soil around the pipe is filled up to the middle of the pipe.
- Type 3

The pipe is laid on a soft clay layer at a height of 10 cm. The soil around the pipe is crushed to the height of the canopy.
- Type 4

The pipe is laid on a layer of sand with a minimum thickness of 10cm. around the pipe granular material is poured up to the height of the canopy and is compressed to 80% in accordance with Proctor's standard AASHTO T-99.
- Type 5

A layer of granular materials is dumped at a thickness of 10cm below the pipe to the height of the canopy, and up to 90% are compressed according to Proctor's standard, AASHTO T-99.

Minimum Laying Condition for C-Class Ductile Iron Pipes vs Depth of Cover (with traffic load)

	C50						C40								
	DN						H (m)	DN					H (m)		
	300	250	200	150	100			600	500	400	350			300	250
						0.5									0.5
						1									1
						1.5									1.5
						2									2
						2.5									2.5
						3									3
						3.5									3.5
						4									4
						4.5									4.5
						5									5
					5.5									5.5	
					6									6	
					7									7	
					8									8	
					9									9	
					10									10	

- Type 1 ■
- Type 2 ■
- Type 3 ■
- Type 4 ■
- Type 5 ■



Angular Deviation Table for Ductile Iron Pipes

K₉/C
Class

LMI Co.

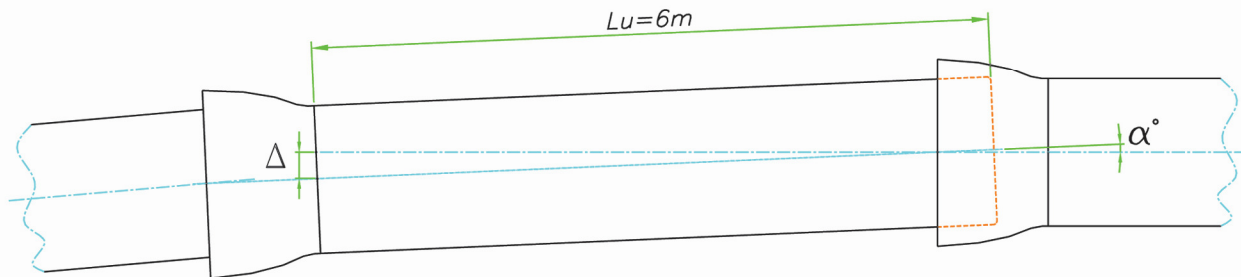
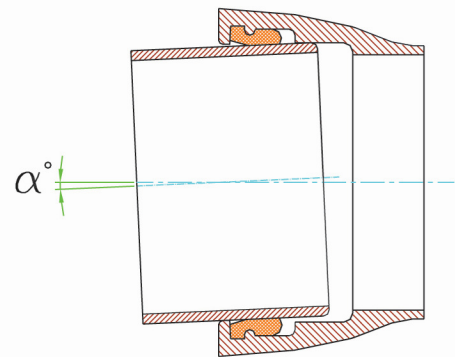

DN	Maximum permissible angular deviation (α)	Displacement at the end of the 6 meter pipe (Δ)
100 - 300	5°	50 cm
350 - 400	4°	40 cm
500 - 1000	3°	30 cm
1100 - 1200	2°	20 cm
1400 - 2000	1°	10 cm

Some Projects

L.M.I



Qatar - Doha

Water transmission weatern taxiway

Diameter: 1200 mm

Year: 2020



Iran - Khorasan e Razavi

Five - Meter depth (civil project)

Diameter: 1200 - 1600 mm

Year: 2019



Iran - West Azarbaijan

Water transmission from the Aras River to the dam Karamabad

Diameter: 2000 mm

Year: 2018



Iran - Bushehr

Water salt remover project (Desalination)

Diameter: 1800 mm

Year: 2018



Iran - Lorestan

Water transmission to Ivashan

Diameter: 1800 mm

Year: 2015



Iraq - Basra

Crossing the river DIP earthquake resistant

Diameter: 800 mm

Year: 2012



Iran - Sistan and Baluchestan

Water transmission from wells halfway Zabul

Diameter: 1200 mm

Year: 2009





LMI Co.